



6532 Tower Lane, Claremore, OK 74019
 PHONE (877)-728 3278 FAX (877)-203-1998
 (A Division of Acme Manufacturing Corp.)

Roof Hatch For Metal Roof

STANDARD FEATURES

Standard 14 ga. galvanized roof hatch built into metal roof curb shell custom built for roof application.

Hatch features 1" insulation, steel butt hinges, latching inside handle, outside push-button release, weather seal and padlock hasp. Cover has a 22 ga. galvanized liner.

Fits opening of 30" X 36"

Curb shell constructed of 18 ga. galv. steel with continuous welded seams and integral base plate for water tight construction and extra strength and pitched to match roof.

Curb shell has factory welded water tight rib pockets to match roof profile and is designed for installation on top of the panel. (Curb position relative to roof ribs **MUST** be determined prior to order.)

3½" wide base flashing on sides to cover roof panel.

Upper flashing is 8" wide with cricket style water diverter welded to base.

Height of 12"

OPTIONS

- Aluminum hatch and curb.
- Other curb styles

PROJECT	
LOCATION	
ARCHITECT	
ENGINEER	
CONTRACTOR	
SUBMITTED BY	
DATE	PO#

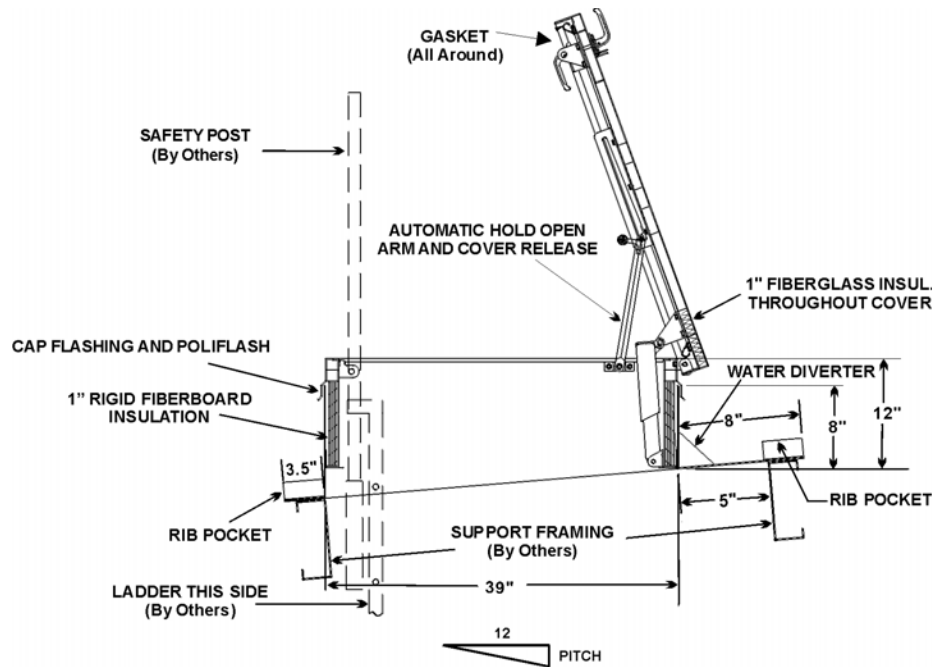

REF.	QUAN	I.D. L x W (Opening)	O.D. L x W	H	Pitch	Pitch Side (L or W)	ROOF PANEL INFO	OPTIONS
		36" x 30"	39" x 33"	12"				