



6532 Tower Lane, Claremore, OK 74019  
 PHONE (877)-728 3278 FAX (877)-203-1998  
 (A Division of Acme Manufacturing Corp.)

## Metal Roof Curb With Loose Clips Type FCMR-2

### STANDARD FEATURES

Loose "Clips" for field location of rib pockets when curb position relative to roof ribs cannot be determined prior to order. DEK-CAP™ end-cap flashing supplied for standing-seam roof panels. Factory welded clips supplied for R-panel roofs.

Constructed of 18 ga. galv. steel with continuous welded seams and integral base plate for water tightness and extra strength.

3½" wide base flashing on sides to cover roof panel.

Upper flashing is 8" wide with cricket style water diverter welded to base.

Lined with 1½" fiberglass fire proof sound attenuating thermal insulation.

Top ledge covered with ¼" polystyrene gasket for weather seal and to reduce metal to metal conducted noise.

Minimum curb height is 8" on the shortest vertical height.

### OPTIONS

- Constructed of 18 ga. galvalume steel or .063 aluminum.
- Interior metal liner.
- 1½" wood nailer secured to top ledge of curb in lieu of gasket.
- Standard heights of 12, 14, 16, 18, 20, 24", or any special height.
- Damper shelf – standard or custom size opening.
- Back draft damper; Damper motor, 120, 240, or 480 vac.
- Security bars.
- Protective or decorative coatings.

PROJECT	
LOCATION	
ARCHITECT	
ENGINEER	
CONTRACTOR	
SUBMITTED BY	
DATE	PO#

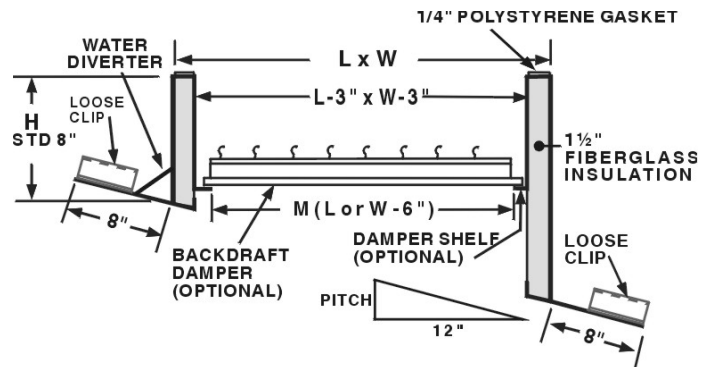
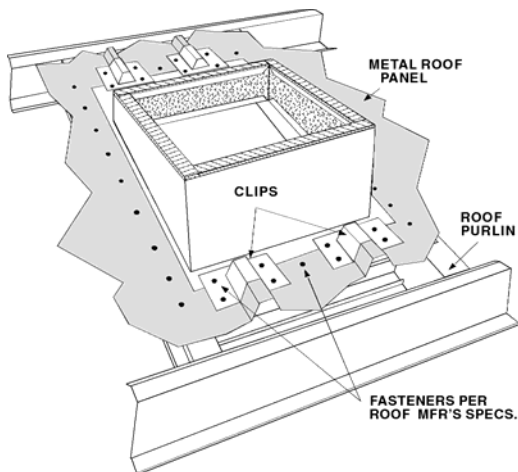

Damper shelf supported from top ledge of curb, but supported from base of curb when total rise over length > 2".

### SPECIFICATIONS AND DIMENSIONS

REFERENCE	QUAN.	L (Pitch Side)	W	H	PITCH	OPTIONS