



6532 Tower Lane, Claremore, OK 74019
 PHONE (877)-728 3278 FAX (877)-203-1998
 (A Division of Acme Manufacturing Corp.)

Metal Roof Curb Welded Clip Type FCMR-1

STANDARD FEATURES

- Factory welded water tight rib pockets. Curb position relative to roof ribs **MUST** be determined prior to order.
- Constructed of 18 ga. galv. steel with continuous welded seams and integral base plate for water tight construction and extra strength.
- 3½" wide base flashing on sides to cover roof panel.
- Upper flashing is 8" wide with cricket style water diverter welded to base.
- Lined with 1½" fiberglass fire proof sound attenuating thermal insulation.
- Top ledge covered with ¼" polystyrene gasket for weather seal and to reduce metal to metal conducted noise.
- Minimum curb height is 8" on the shortest vertical height.

PROJECT	
LOCATION	
ARCHITECT	
ENGINEER	
CONTRACTOR	
SUBMITTED BY	
DATE	PO#

OPTIONS

- Constructed of 18 ga. galvalume steel or .063 aluminum.
- Interior metal liner.
- Standard heights of 12, 14, 16, 18, 20, 24", or any special height.
- Damper shelf – standard or custom size opening.
- Back draft damper; Damper motor, 120, 240, or 480 vac.
- Security bars.
- Protective or decorative coatings.

**THIS CURB IS DESIGNED FOR
 INSTALLATION ON TOP OF THE ROOFING.**

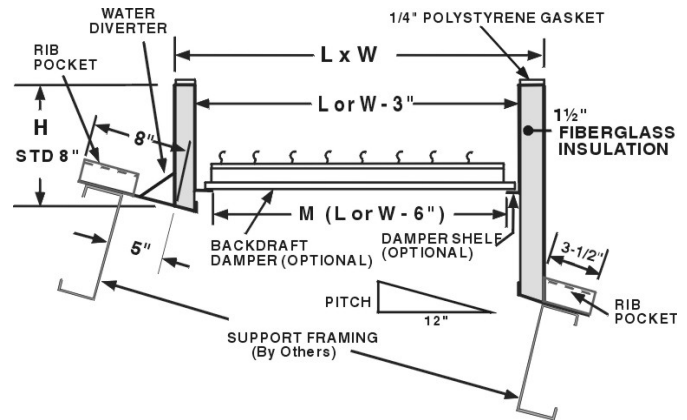
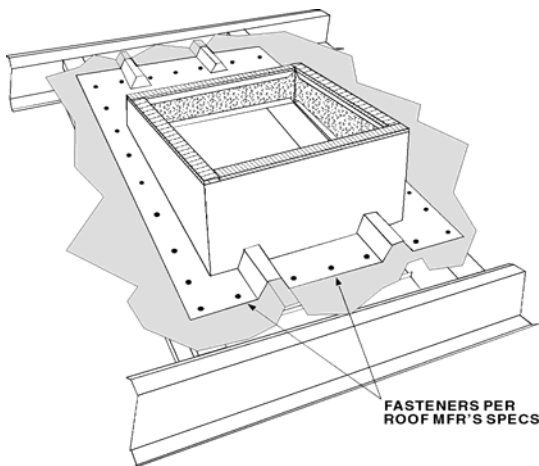

Damper shelf supported from top ledge of curb, but supported from base of curb when total rise over length > 2".

SPECIFICATIONS AND DIMENSIONS

REFERENCE	QUAN.	L (Pitch Side)	W	H	PITCH	OPTIONS