



6532 TOWER LANE, CLAREMORE, OK. 74019
 Phone: 877-728-3278 Fax: 877-203-1998
 [A Division of Acme Mfg. Corp.]

**Metal Roof Curb
 Welded Clip
 Type FCMR-1
 (Over/Under)**

Type FCMR-1 - OVER/UNDER INSTALLATION INSTRUCTIONS

FOR INSTALLATION ON TOP OF A NEW ROOF

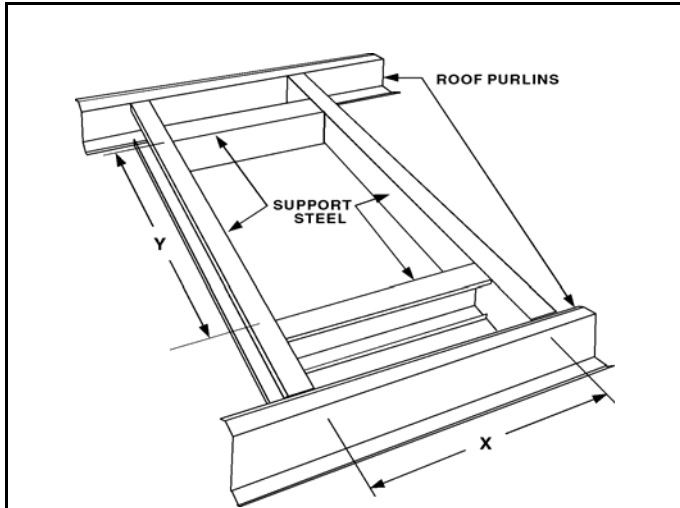

STEP 1

After building framing is complete, locate roof opening and install support framing for roof curb and equipment loads in accordance with building engineer's specifications. See "**TYPICAL FRAMED OPENING DETAILS**" sheet for recommended X and Y dimensions.

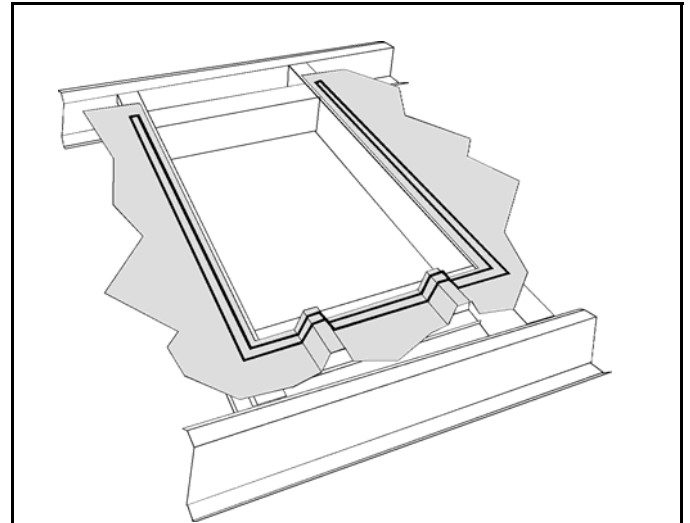

STEP 2

Cut lower roof panels to fit opening of curb on sloping sides and with ribs overlapping eave side curb flanges by 3/2". Apply a minimum of two rows of sealant tape on the top side of the roof panels.

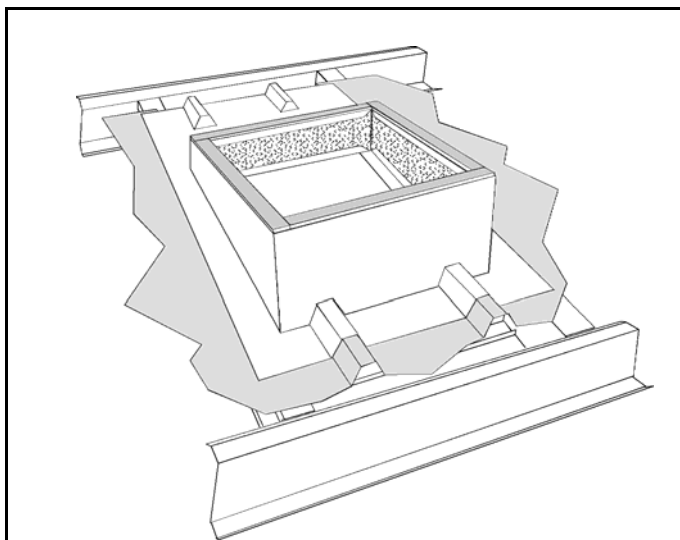

STEP 3

Set curb on top of sealant tape and press firmly into place.

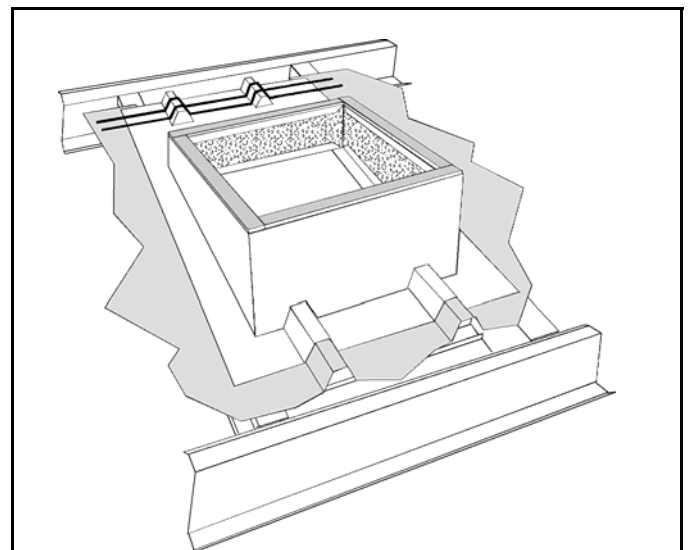

STEP 4

Apply at least two rows of sealant tape across the curb flange and ribs on the ridge side of the curb.



6532 TOWER LANE, CLAREMORE, OK. 74019
Phone: 877-728-3278 Fax: 877-203-1998
[A Division of Acme Mfg. Corp.]

Metal Roof Curb Welded Clip Type FCMR-1 (Over/Under)

Type FCMR-1 - OVER/UNDER INSTALLATION INSTRUCTIONS

FOR INSTALLATION ON TOP OF A NEW ROOF

