



6532 TOWER LANE, CLAREMORE, OK. 74019
 Phone: 877-728-3278 Fax: 877-203-1998
 (A Division of Acme Mfg. Corp.)

Metal Roof Curb Welded Clip Type FCMR-1

Type FCMR-1 INSTALLATION INSTRUCTIONS

FOR INSTALLATION ON TOP OF A NEW OR EXISTING ROOF

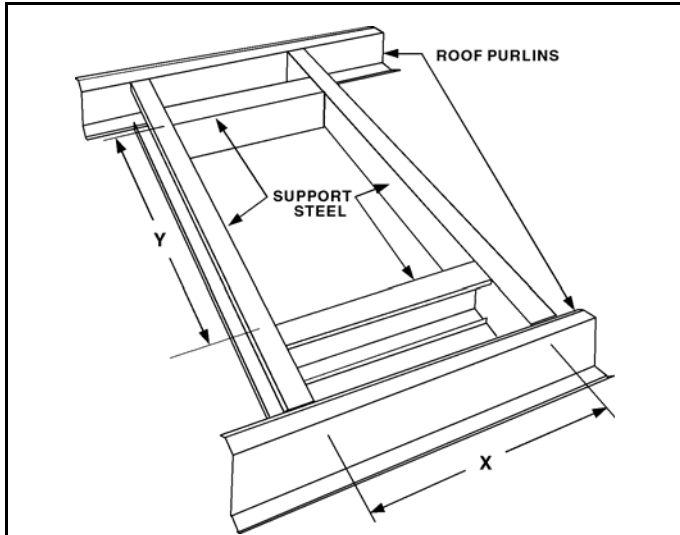

STEP 1

After building framing is complete, locate roof opening and install support framing for roof curb and equipment loads in accordance with building engineer's specifications. See "**TYPICAL FRAMED OPENING DETAILS**" sheet for recommended X and Y dimensions.

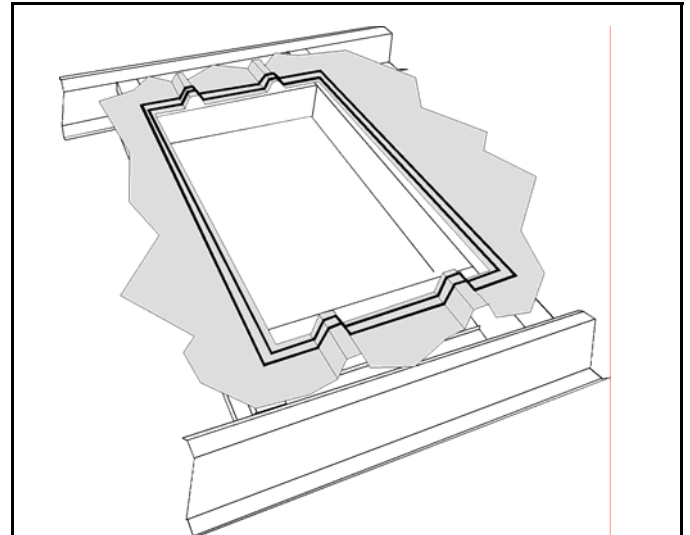

STEP 2

Cut roof panels to fit opening of curb on sloping sides and with ribs overlapping curb flanges by 3½" on eave and ridge sides of curb. Apply a minimum of two rows of sealant tape on the top side of the roof panels.

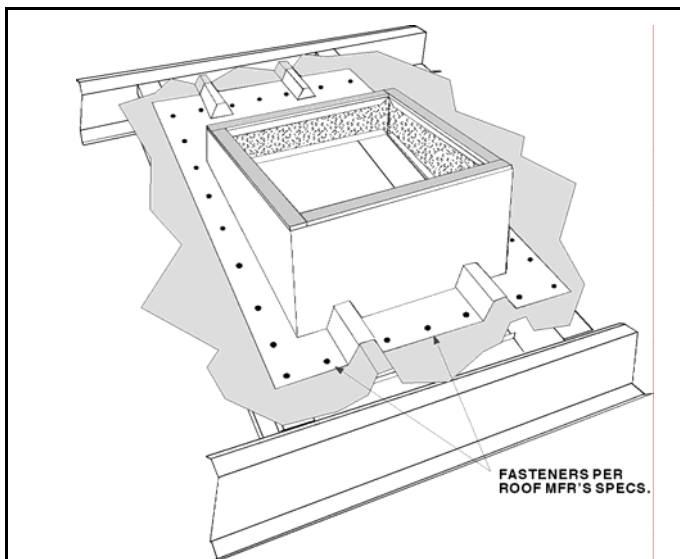

STEP 3

Set curb on top of sealant tape and press firmly into place. Install fasteners compatible with the roof system at a minimum of 6" on center.

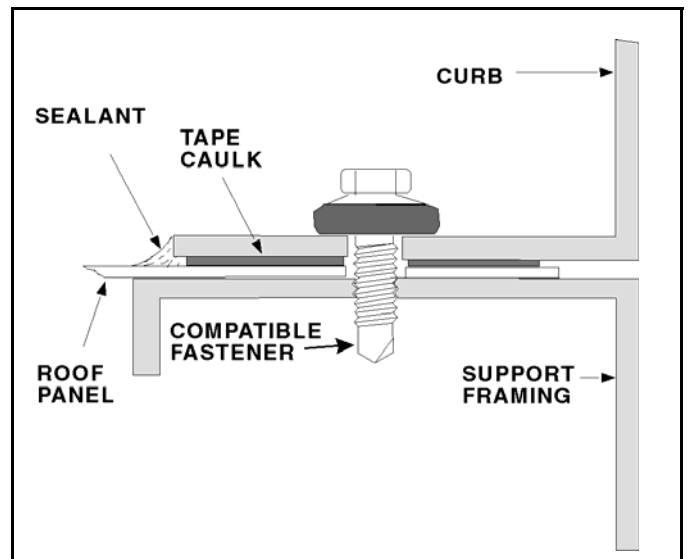

STEP 4

Inspect installation and fasteners. Finish edge of curb and all mechanical joints with a good grade of sealant to assure a watertight seal. **MAKE SURE ALL POSSIBLE OPENINGS FOR WATER ARE SEALED.**