



6532 Tower Lane, Claremore, OK 74019
 PHONE (877)-728 3278 FAX (877)-203-1998
 (A Division of Acme Manufacturing Corp.)

Pipe Box Assembly Curb Type PB-1, PB-2 & PB-3

STANDARD FEATURES

Shell and base plate constructed of 18 ga. galv steel with continuous welded seams for water tightness and extra strength.

Lined with 1½" fiberglass fire proof thermal insulation.

Internal angle reinforcing.

Welds coated with chrome enamel.

3" cant on PB-1 & PB-2.

Raised cant for deck insulation on PB-1.

Factory installed wood nailer.

Pipe Box constructed of 20 ga. galv. steel with 1" rigid insulation.

PROJECT	
LOCATION	
ARCHITECT	
ENGINEER	
CONTRACTOR	
SUBMITTED BY	
DATE	PO#

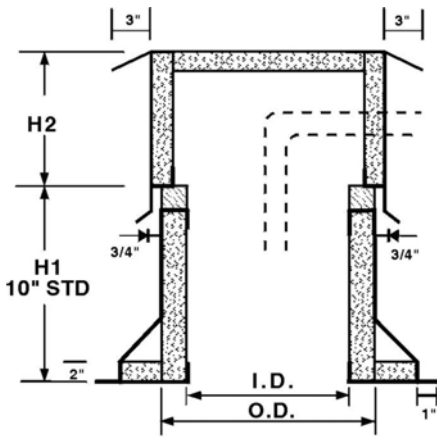

Model PB-1

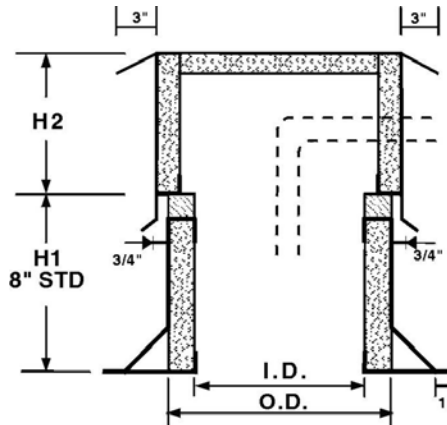

Model PB-2

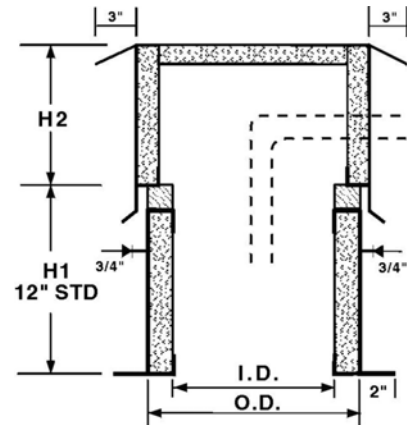

Model PB-3

SPECIFICATIONS AND DIMENSIONS

REFERENCE	QUAN.	MODEL NO.	O.D.	I.D.	H ¹	H ²