



6532 Tower Lane, Claremore, OK 74019
 PHONE (877)-728 3278 FAX (877)-203-1998
 (A Division of Acme Manufacturing Corp.)

Pitched Self-Flashing Curb Type FCSP

STANDARD FEATURES

Constructed of 18 ga. galv. steel with continuous welded seams and integral base plate for water tightness and extra strength.

Lined with 1½" fiberglass fire proof sound attenuating type insulation.

2 x 2 treated wood nailer

Custom sizes with any roof pitch.

Standard curb height is 12" on the shortest vertical height.

OPTIONS

- Constructed of .063" aluminum.
- Interior metal liner.
- Heights of 8, 14, 16, 18, 20, 24", or any special height.
- Damper shelf – standard or custom size opening.
- Protective or decorative coatings.
- Heavy-gage construction.

PROJECT	
LOCATION	
ARCHITECT	
ENGINEER	
CONTRACTOR	
SUBMITTED BY	
DATE	PO#

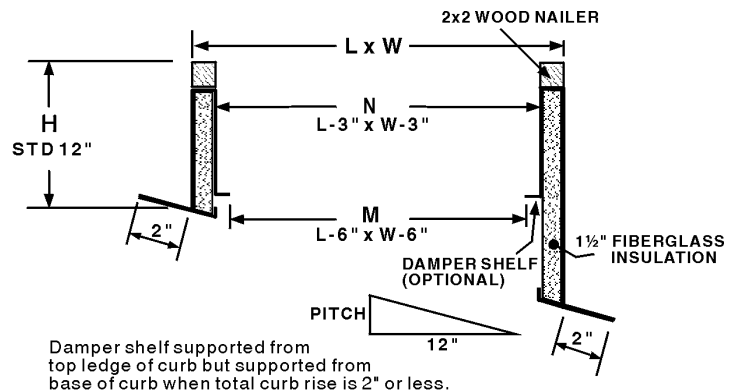
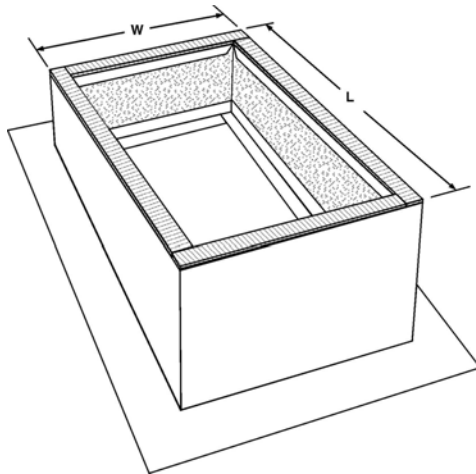

NOTE: Curb is pitched along "L" dimension

SPECIFICATIONS AND DIMENSIONS

REFERENCE	QUAN.	MAT'L	L Pitch Side	W	M	H	OPTIONS