



6532 Tower Lane, Claremore, OK 74019
 PHONE (877)-728 3278 FAX (877)-203-1998
 (A Division of Acme Manufacturing Corp.)

Self-Flashing Curb Type FCS Custom Sizes

STANDARD FEATURES

Constructed of 18 ga. galv. steel with continuous welded seams and integral base plate for water tightness and extra strength.

Lined with 1½" fiberglass fire proof sound attenuating thermal insulation.

2 x 2 treated wood nailer secured to top ledge of curb.

OPTIONS

- Constructed of .063" aluminum or 304 stainless steel.
- Interior metal liner.
- Heights of 8, 14, 16, 18, 20, 24", or any special height.
- Damper shelf – standard or custom size opening.
- Wide flange (6" or 8" wide).
- Protective or decorative coatings.
- Heavy-gage construction.

PROJECT	
LOCATION	
ARCHITECT	
ENGINEER	
CONTRACTOR	
SUBMITTED BY	
DATE	PO#

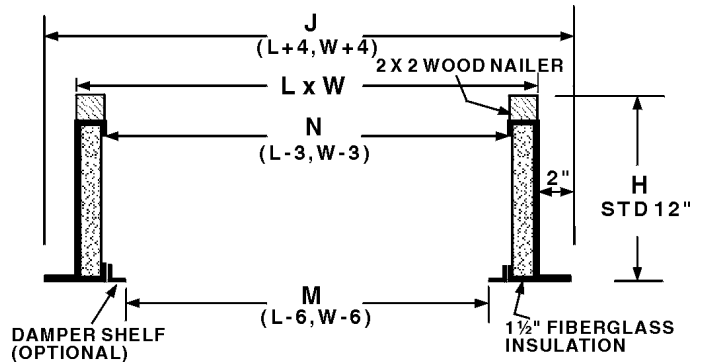
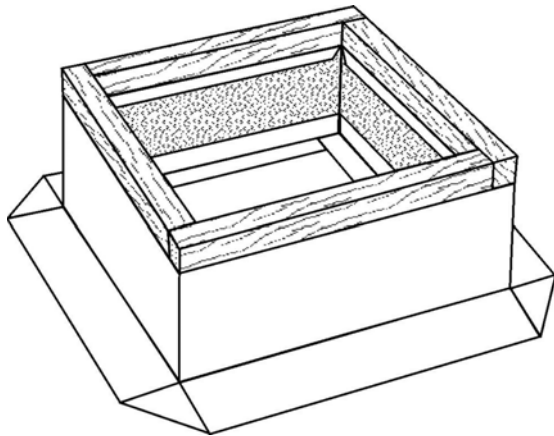

SPECIFICATIONS AND DIMENSIONS

REFERENCE	QUAN.	MAT'L	L	W	N	M	H	OPTIONS